



**CETEC**

Connect and Drive the World

**CONVEYOR BELT**

**SUPPLY**

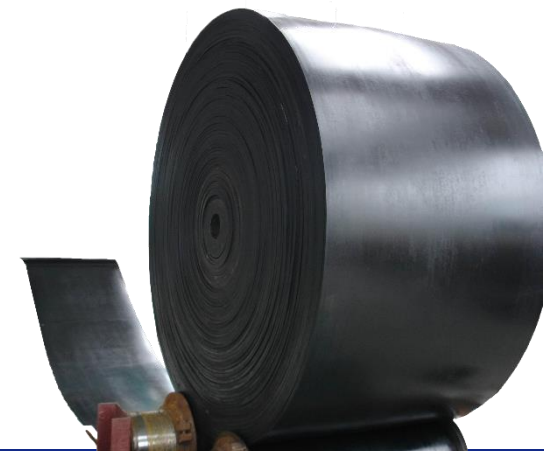

# CONTENT

- ◆ CETEC & China Belt Suppliers
- ◆ Advanced Workshop Equipment
- ◆ Five-Star Technology
- ◆ Top Raw Materials
- ◆ Product
- ◆ Complete Service
- ◆ Project
- ◆ Achievements

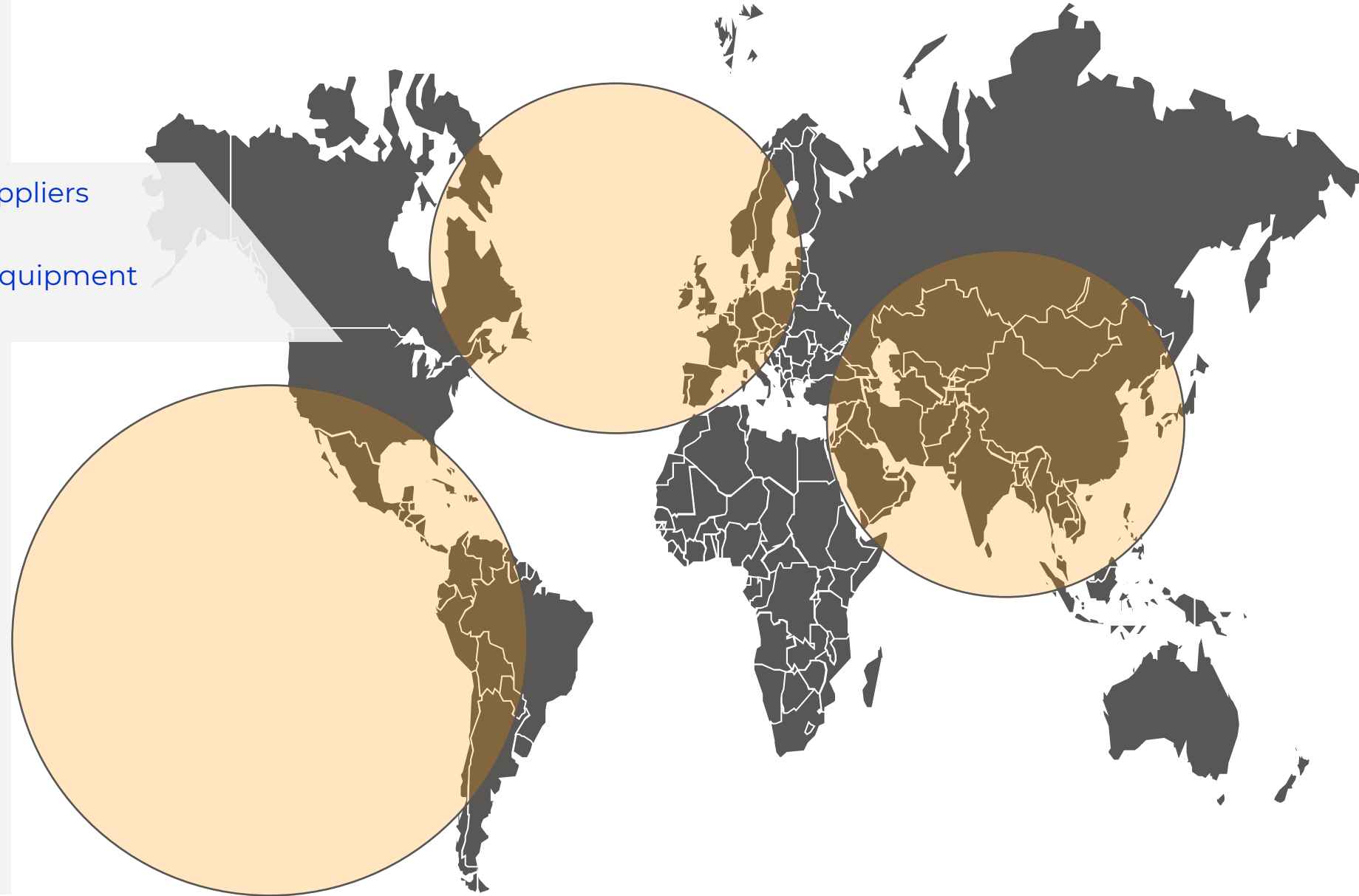

## Advantages of Belting Supply from China

Chinese belt manufacturers provide OEM to **Metso, Dunlop, Goodyear, Contitech, Pheonix** company with **International Code DIN/ISO/AS/SANS/JIS** etc.

Both China Made **International Brand and China Top Brand** Available

Annual production capacity is around **100 million** <sup>m<sup>2</sup></sup>  
Plied textile belts (**EP, NN**, CC and Aramid),  
Solid woven belts (**PVC, PVG**, PVNi, and PYNA),  
Steel Cord (**ST**) Belt  
**Heat resistant belts, Cord Resistant Belt, Tube belts,etc.**

### **Cost Savings:**

- Economy of scale
- Low materials cost in China (for both rubber and structural materials)
- Lower cost of resources in China (labor, material chain, etc)
- Severe domestic market competition
- Professional Advice from Belt Conveyor Designer and User.

- Integrated Solution Provider in **Bulk Material Handling and Cement**
- Professional Technical Team for **International Projects**
- **Customized & Optimized** Conveyor Solution

The logo for CETEC, featuring the word "CETEC" in a bold, white, sans-serif font. The letters "C", "E", and "T" are contained within a dark blue rectangular box, while the letters "E", "T", and "C" are positioned to the right of this box, creating a layered effect.

# PARTNER

- World's Largest Rubber Producer
- Best Selection in Different Conditions
- Complete Solution for Cement , Mining, Port Industry



# Advanced Workshop Equipment



Core knitting machine -UK Wilson



Core knitting machine -GER Jorgen



Canvas rubber thread -SPA



Core dipped plastic line - FRA



GN-400L Rubber Mixer - KRUPP



Rubber mixing microcomputer monitoring room

# Five Star Technology

World's **First** T4 to 175°C heat resistant steel cord pipe belt



World's **Longest** overland conveyor system 160km



China **Largest** single roll 6m\*3.2m\*4m, 80tons

China's **Strongest** solid woven conveyor belt PVG3150



China produced **Widest** steel cord conveyor belt ST3500-3100mm

# Top Raw Materials

Ribbed Smoked Sheets  
Neoprene



**Colloid**



From UK & Detex  
Bekaert



**Framework Material**



High Abrasion Resistance  
Insoluble Sulfur



**Auxiliaries**



# Product

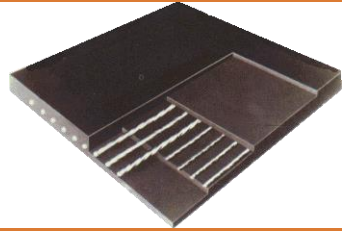

Steel Cord Conveyor Belts



Solid Woven Conveyor Belts



Pipe Conveyor Belts



Heat Resistant Conveyor Belts



Fabric Conveyor Belts



Profiled Conveyor Belts



Profiled Conveyor Belts

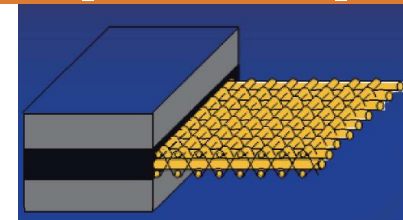

Aramid Conveyor Belts



# Steel Cord Belt



- ❖ Tensile Strength: ST500~ST7500N/mm
- ❖ Belt width : 500~2500mm
- ❖ Comply with ISO/JIS/DIN/AS/BS/RMA/GB codes



General applications Steel Cord Belt  
This type of belt is for normal working conditions.

# Steel Cord Belt with Rip Resistant

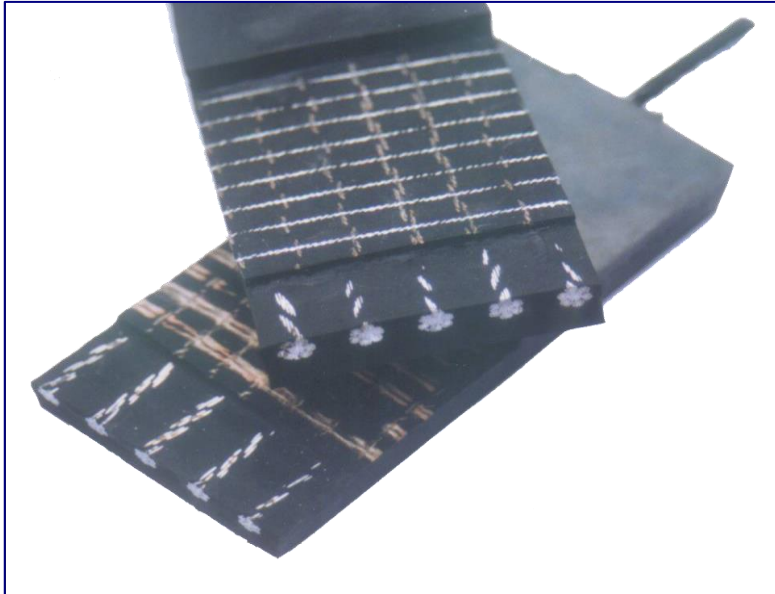

Steel Cords in Longitudinal direction

HE Steel Breaker, Strength: 125-800N/mm

Nylon Fabric Breaker, Strength: 50—80N/mm

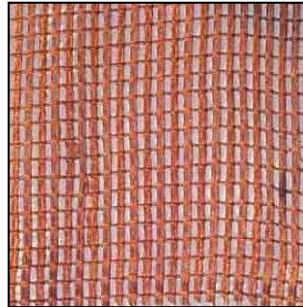

# Steel Cord Belt for Special Working Conditions

Classified by cover rubber grade

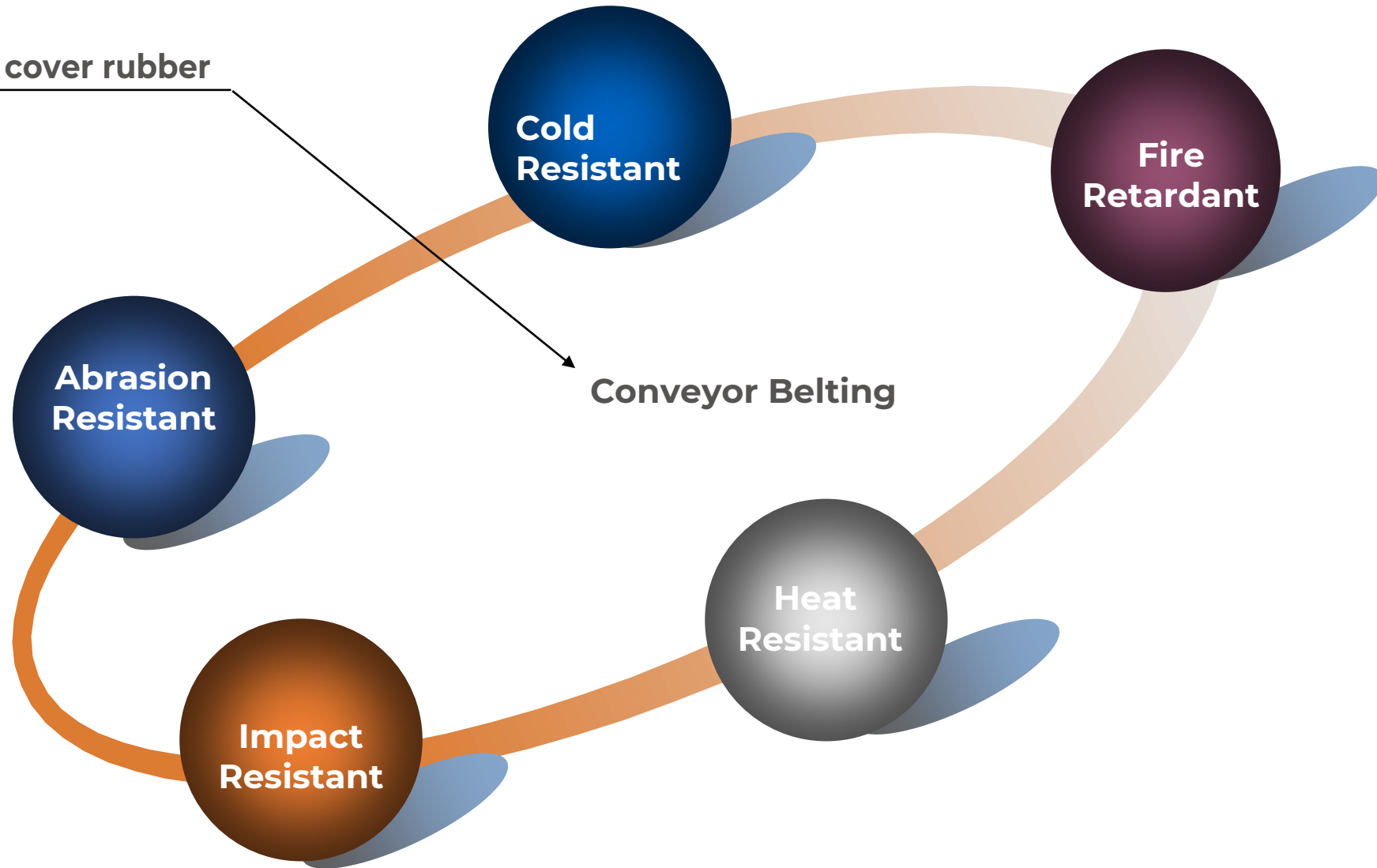

# Steel Cord Belt DIN22131 , Cover Grade W-X-Y-K

| Tensile Rating            | ST1000         | ST1250       | ST1600 | ST2000 | ST2500 | ST3150 | ST3500 | ST4000 | ST4500 | ST5000 | ... |  |
|---------------------------|----------------|--------------|--------|--------|--------|--------|--------|--------|--------|--------|-----|--|
| Long. Tensile $\geq n/mm$ | 1000           | 1250         | 1600   | 2000   | 2500   | 3150   | 3500   | 4000   | 4500   | 5000   |     |  |
| Max. Cord Dia. mm         | 4.1            | 4.9          | 5.6    | 5.6    | 7.2    | 8.1    | 8.6    | 8.9    | 9.7    | 10.9   |     |  |
| Supply Cord Dia.mm        | 3.6            | 4.4          | 5.2    | 5.2    | 6.8    | 7.7    | 8.1    | 8.6    | 9.5    | 10.3   |     |  |
| Cable pitch mm $\pm 15$   | 12             | 14           | 15     | 12     | 15     | 15     | 15     | 15     | 16     | 17     |     |  |
| Min. Cover Tks mm         | 4              | 4            | 4      | 4      | 5      | 5.5    | 6      | 6.5    | 7      | 7.5    |     |  |
| Belt Width (mm)           | Deviation (mm) | No. Of cords |        |        |        |        |        |        |        |        |     |  |
| 500                       | $\pm 5$        | 39           | 34     | N/A    | N/A    | N/A    | N/A    | N/A    | N/A    | N/A    | N/A |  |
| 650                       | $\pm 7$        | 51           | 44     | N/A    | N/A    | N/A    | N/A    | N/A    | N/A    | N/A    | N/A |  |
| 800                       | $\pm 8$        | 64           | 55     | 50     | 64     | N/A    | N/A    | N/A    | N/A    | N/A    | N/A |  |
| 1000                      | $\pm 10$       | 81           | 69     | 64     | 81     | 64     | 64     | 64     | 64     | 59     | 55  |  |
| 1200                      | $\pm 10$       | 97           | 84     | 77     | 81     | 77     | 77     | 77     | 77     | 71     | 66  |  |
| 1400                      | $\pm 12$       | 114          | 98     | 90     | 114    | 90     | 90     | 90     | 90     | 84     | 78  |  |
| 1600                      | $\pm 12$       | 131          | 112    | 104    | 131    | 104    | 104    | 104    | 104    | 96     | 90  |  |
| 1800                      | $\pm 14$       | 147          | 127    | 117    | 147    | 117    | 117    | 117    | 117    | 109    | 102 |  |
| 2000                      | $\pm 14$       | 164          | 141    | 130    | 164    | 130    | 130    | 130    | 130    | 121    | 113 |  |
| 2200                      | $\pm 15$       | 181          | 155    | 144    | 181    | 144    | 144    | 144    | 144    | 134    | 125 |  |

# Steel Cord Belt GB/T 9770-2013, Cover Grade H-D-L

| Tensile Rating             | ST 500       | ST 630       | ST 800 | ST 1000 | ST 1250 | ST 1400 | ST 1600 | ST 1800 | ST 2000 | ST 2250 | ST 2500 | ST 2800 | ST 3150 | ST 3500 | ST 4000 | ST 4500 | ST 5000 |     |
|----------------------------|--------------|--------------|--------|---------|---------|---------|---------|---------|---------|---------|---------|---------|---------|---------|---------|---------|---------|-----|
| Long. Tensile $\geq$ n/mm  | 500          | 630          | 800    | 1000    | 1250    | 1400    | 1600    | 1800    | 2000    | 2250    | 2500    | 2800    | 3150    | 3500    | 4000    | 4500    | 5000    |     |
| Max.Cord Dia. mm           | 3.0          | 3.0          | 3.5    | 4.0     | 4.5     | 5.0     | 5.6     | 6.0     | 5.6     | 7.2     | 7.2     | 7.2     | 8.1     | 8.6     | 8.9     | 9.7     | 10.9    |     |
| Supply Cord Dia.mm         | 2.8          | 2.8          | 3.0    | 3.4     | 3.8     | 4.4     | 4.4     | 4.6     | 5.0     | 5.2     | 6.6     | 6.6     | 7.3     | 7.3     | 7.7     | 8.2     | 9.0     |     |
| Single cord tensile KN/pcs | 7.6          | 7.0          | 8.9    | 12.9    | 16.1    | 20.6    | 20.6    | 25.5    | 25.6    | 26.2    | 40      | 39.6    | 50.5    | 56.0    | 63.5    | 76.3    | 91.0    |     |
| Cable pitch mm $\pm$ 15    | 14           | 10           | 10     | 12      | 12      | 14      | 12      | 13.5    | 12      | 11      | 15      | 13.5    | 15      | 15      | 15      | 16      | 17      |     |
| Min.Cover Tks mm           | 4            | 4            | 4      | 4       | 4       | 4       | 4       | 4       | 4       | 4       | 5       | 5       | 5.5     | 6       | 6.5     | 7       | 7.5     |     |
| Belt Tks mm                | 10.8         | 10.8         | 11     | 11.4    | 11.8    | 12.4    | 12.4    | 12.8    | 13      | 13.2    | 16.6    | 16.6    | 18.3    | 19.7    | 21.2    | 23      | 24.8    |     |
| Refer.Weight kg/m2         | 15           | 16           | 16.5   | 17      | 18      | 19.5    | 20      | 20.5    | 22      | 23.5    | 29.0    | 30.0    | 32.0    | 35.5    | 38.5    | 42.5    | 47      |     |
| Belt Width mm              | Deviation mm | No. Of cords |        |         |         |         |         |         |         |         |         |         |         |         |         |         |         |     |
| 500                        | +10/-5       | 33           | 45     | 45      | 39      | 39      | 34      | 39      | N/A     | N/A     | N/A     | N/A     | N/A     | N/A     | N/A     | N/A     | N/A     | N/A |
| 650                        | +10/-7       | 44           | 60     | 60      | 51      | 51      | 45      | 51      | 46      | 52      | 56      | 41      | 46      | 41      | 41      | 41      | 39      | 36  |
| 800                        | +10/-8       | 50           | 75     | 75      | 63      | 63      | 55      | 63      | 57      | 63      | 69      | 50      | 57      | 50      | 50      | 50      | 48      | 45  |
| 1000                       | $\pm$ 10     | 68           | 95     | 95      | 79      | 95      | 68      | 79      | 71      | 79      | 86      | 64      | 71      | 64      | 64      | 64      | 59      | 55  |
| 1200                       | $\pm$ 10     | 83           | 113    | 113     | 94      | 94      | 82      | 94      | 85      | 94      | 104     | 76      | 85      | 76      | 77      | 77      | 71      | 66  |
| 1400                       | $\pm$ 12     | 96           | 133    | 133     | 111     | 111     | 97      | 111     | 100     | 111     | 122     | 89      | 99      | 89      | 90      | 90      | 84      | 78  |
| 1600                       | $\pm$ 12     | 111          | 151    | 151     | 126     | 126     | 111     | 126     | 114     | 126     | 140     | 101     | 114     | 101     | 104     | 104     | 96      | 90  |
| 1800                       | $\pm$ 14     | 125          | 171    | 171     | 143     | 143     | 125     | 143     | 129     | 143     | 159     | 114     | 128     | 114     | 117     | 117     | 109     | 102 |
| 2000                       | $\pm$ 14     | 139          | 191    | 191     | 159     | 159     | 139     | 159     | 144     | 159     | 177     | 128     | 143     | 128     | 130     | 130     | 121     | 113 |
| 2200                       | $\pm$ 15     | 153          | 211    | 211     | 176     | 176     | 154     | 176     | 159     | 176     | 195     | 141     | 158     | 141     | 144     | 144     | 134     | 125 |

# Fabric Plied Conveyor Belting

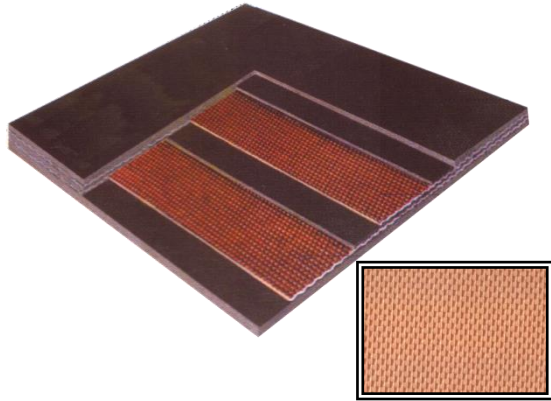

**EP Plied Belting**

Features:

- 1.Low loading extension rate
- 2.Good flexible and abrasion resistant performance
- 3.Anti-heat and humidity, acid and alkaline-resistance

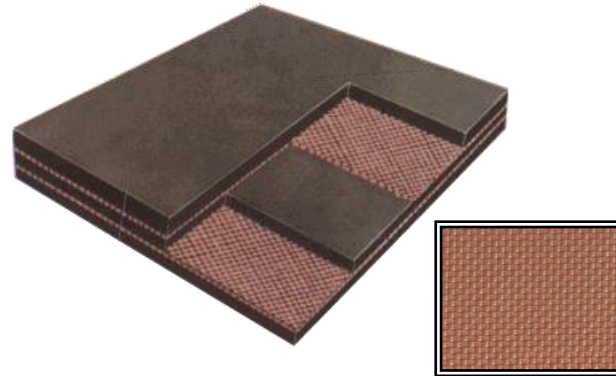

**NN Plied Belting**

Features:

- 1.Light and high strength of the carcass with good flexible flexor.
2. Easy to trough and track, good flexibility and impact resistant
- 3.Anti- heat and humidity, acid and alkaline-resistance

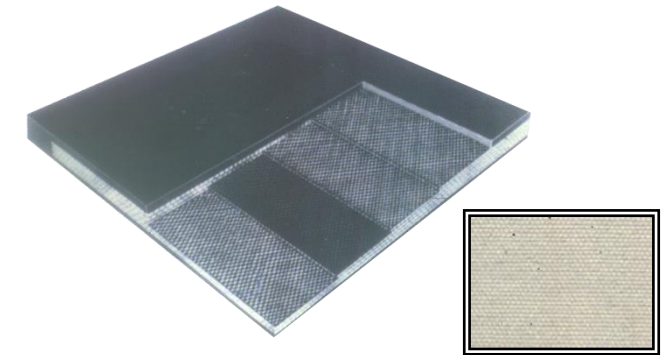

**CC Plied Belting**

Features:

- 1.Good tire resistant performance
2. Low extension rate
- 3.Suitable for big slope transportation

# Fabric Plied Conveyor Belting

Comply with ISO/JIS/DIN/AS/BS/RMA/GB codes

Impact Resistant/Heat Resistant/Oil Resistant/Acid,Alkali Resistant /Fire Retardant etc.

| Belt Type | Fabric | Min.Ply strength (N/mm) | Piles | Top Cover (mm) | Bottom Cover(mm) | Belt Width(mm/inch) |     |     |     |     |      |      |      |      |      |      |      |      |     |
|-----------|--------|-------------------------|-------|----------------|------------------|---------------------|-----|-----|-----|-----|------|------|------|------|------|------|------|------|-----|
|           |        |                         |       |                |                  | 500                 | 600 | 700 | 800 | 900 | 1000 | 1050 | 1200 | 1400 | 1600 | 1800 | 2000 | 2200 |     |
|           |        |                         |       |                |                  | 20                  | 24  | 28  | 32  | 36  | 40   | 42   | 48   | 56   | 64   | 72   | 80   | 88   |     |
| EP Belts  | EP100  | 100                     | 2-6   | 2-25           | 0-15             | Yes                 | Yes | Yes | Yes | Yes | Yes  | Yes  | Yes  | Yes  | Yes  | Yes  | Yes  | Yes  | Yes |
|           | EP125  | 125                     | 2-6   | 2-25           | 0-15             | Yes                 | Yes | Yes | Yes | Yes | Yes  | Yes  | Yes  | Yes  | Yes  | Yes  | Yes  | Yes  | Yes |
|           | EP150  | 150                     | 2-6   | 2-25           | 0-15             | Yes                 | Yes | Yes | Yes | Yes | Yes  | Yes  | Yes  | Yes  | Yes  | Yes  | Yes  | Yes  | Yes |
|           | EP200  | 200                     | 2-6   | 2-25           | 0-15             | Yes                 | Yes | Yes | Yes | Yes | Yes  | Yes  | Yes  | Yes  | Yes  | Yes  | Yes  | Yes  | Yes |
|           | EP250  | 250                     | 2-6   | 2-25           | 0-15             | Yes                 | Yes | Yes | Yes | Yes | Yes  | Yes  | Yes  | Yes  | Yes  | Yes  | Yes  | Yes  | Yes |
|           | EP300  | 300                     | 2-6   | 2-25           | 0-15             | Yes                 | Yes | Yes | Yes | Yes | Yes  | Yes  | Yes  | Yes  | Yes  | Yes  | Yes  | Yes  | Yes |
|           | EP350  | 350                     | 2-6   | 2-25           | 0-15             | Yes                 | Yes | Yes | Yes | Yes | Yes  | Yes  | Yes  | Yes  | Yes  | Yes  | Yes  | Yes  | Yes |
|           | EP400  | 400                     | 2-6   | 2-25           | 0-15             | Yes                 | Yes | Yes | Yes | Yes | Yes  | Yes  | Yes  | Yes  | Yes  | Yes  | Yes  | Yes  | Yes |
|           | EP500  | 500                     | 2-6   | 2-25           | 0-15             | Yes                 | Yes | Yes | Yes | Yes | Yes  | Yes  | Yes  | Yes  | Yes  | Yes  | Yes  | Yes  | Yes |
| EP600     | 600    | 2-6                     | 2-25  | 0-15           | Yes              | Yes                 | Yes | Yes | Yes | Yes | Yes  | Yes  | Yes  | Yes  | Yes  | Yes  | Yes  | Yes  |     |
| NN Belt   | NN100  | 100                     | 2-8   | 2-25           | 0-15             | Yes                 | Yes | Yes | Yes | Yes | Yes  | Yes  | Yes  | Yes  | Yes  | Yes  | Yes  | Yes  | Yes |
|           | NN125  | 125                     | 2-8   | 2-25           | 0-15             | Yes                 | Yes | Yes | Yes | Yes | Yes  | Yes  | Yes  | Yes  | Yes  | Yes  | Yes  | Yes  | Yes |
|           | NN150  | 150                     | 2-8   | 2-25           | 0-15             | Yes                 | Yes | Yes | Yes | Yes | Yes  | Yes  | Yes  | Yes  | Yes  | Yes  | Yes  | Yes  | Yes |
|           | NN200  | 200                     | 2-8   | 2-25           | 0-15             | Yes                 | Yes | Yes | Yes | Yes | Yes  | Yes  | Yes  | Yes  | Yes  | Yes  | Yes  | Yes  | Yes |
|           | NN250  | 250                     | 2-8   | 2-25           | 0-15             | Yes                 | Yes | Yes | Yes | Yes | Yes  | Yes  | Yes  | Yes  | Yes  | Yes  | Yes  | Yes  | Yes |
|           | NN300  | 300                     | 2-8   | 2-25           | 0-15             | Yes                 | Yes | Yes | Yes | Yes | Yes  | Yes  | Yes  | Yes  | Yes  | Yes  | Yes  | Yes  | Yes |
|           | NN350  | 350                     | 2-8   | 2-25           | 0-15             | Yes                 | Yes | Yes | Yes | Yes | Yes  | Yes  | Yes  | Yes  | Yes  | Yes  | Yes  | Yes  | Yes |
|           | NN400  | 400                     | 2-8   | 2-25           | 0-15             | Yes                 | Yes | Yes | Yes | Yes | Yes  | Yes  | Yes  | Yes  | Yes  | Yes  | Yes  | Yes  | Yes |
|           | NN500  | 500                     | 2-8   | 2-25           | 0-15             | Yes                 | Yes | Yes | Yes | Yes | Yes  | Yes  | Yes  | Yes  | Yes  | Yes  | Yes  | Yes  | Yes |
| NN600     | 600    | 2-8                     | 2-25  | 0-15           | Yes              | Yes                 | Yes | Yes | Yes | Yes | Yes  | Yes  | Yes  | Yes  | Yes  | Yes  | Yes  | Yes  |     |
| CC Belt   | CC-56  | 56                      | 3-12  | 2-25           | 0-15             | Yes                 | Yes | Yes | Yes | Yes | Yes  | Yes  | Yes  | Yes  | Yes  | Yes  | Yes  | Yes  |     |

# Solid Woven Flame-Resistant Conveyor Belt

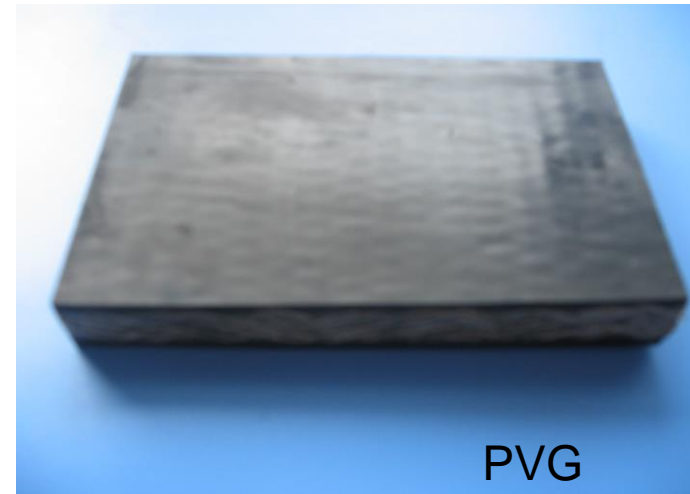
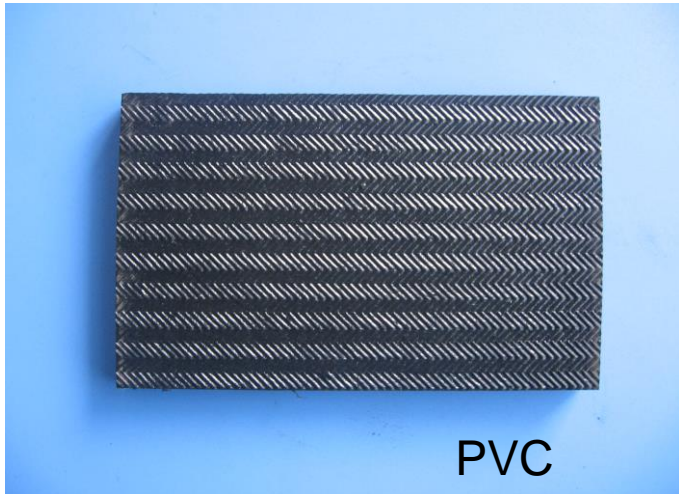

## Product Performance Characteristics

- ◆ Excellent flame resistant
- ◆ Light weight, high tensile strength
- ◆ One carcass with good performance
- ◆ Low elongation, impact resistant,
- ◆ Rip resistant
- ◆ PVC belt for dry operation inclination less than 16 degree
- ◆ PVG belt for wet operation inclination less than 20 degree

## PVC/PVG VS Fire Retardant ST Belt

- ◆ Light weight , less drive power
- ◆ Excellent safety performance
- ◆ Longitudinal direction rip resistant
- ◆ Mechanical splice available



## Solid Woven Flame-Resistant Conveyor Belt

This type of belts could be manufactured according to MT914,SANS 971,AS 4606,BS3289,BC158.etc international codes and regulations.

| Belt Tensile Rating | Warp Tensile(N/m m) | Weft Tensile(N/mm) | Refer.Carcass Tks(mm) | Refer.Carcass Weight(kg/m2) | Grade and Tks(mm) |             | Width(mm) |
|---------------------|---------------------|--------------------|-----------------------|-----------------------------|-------------------|-------------|-----------|
|                     |                     |                    |                       |                             |                   |             |           |
| 680/1 T4            | 680                 | 265                | 6.5                   | 8.5                         | PVC 1.5+1.5       | PVG 1.5+1.5 | 500-3200  |
| 800/1 T5            | 800                 | 280                | 7.0                   | 9.0                         | PVC 1.5+1.5       | PVG 1.5+1.5 | 500-3200  |
| 1000/1 T6           | 1000                | 300                | 8.0                   | 10.5                        | PVC 1.5+1.5       | PVG 1.5+1.5 | 500-3200  |
| 1250/1 T7           | 1250                | 350                | 9.5                   | 12.5                        | PVC 2.0+2.0       | PVG 2.0+1.5 | 500-3200  |
| 1400/1 T8           | 1400                | 350                | 10.0                  | 13.0                        | PVC 2.0+2.0       | PVG 2.5+1.5 | 500-3200  |
| 1600/1 T9           | 1600                | 400                | 10.5                  | 14                          | PVC 2.0+2.0       | PVG 2.5+1.5 | 500-3200  |
| 1800/1 T10          | 1800                | 400                | 11.5                  | 15                          | PVC 2.0+2.0       | PVG 3.0+2.0 | 500-3200  |
| 2000/1 T10          | 2000                | 400                | 12.5                  | 16.5                        | PVC 2.0+2.0       | PVG 3.0+2.0 | 500-3200  |
| 2240/1 T12          | 2240                | 450                | 14.0                  | 18.5                        | PVC 3.0+2.0       | PVG 3.0+2.0 | 500-3200  |
| 2500/1 T13          | 2500                | 450                | 15.0                  | 20.0                        | PVC 3.0+2.0       | PVC 3.0+3.0 | 500-3200  |
| 2800/1 T14          | 2800                | 450                | 16.5                  | 22.0                        | PVC 3.0+3.0       | PVC 5.0+3.0 | 500-3200  |
| 3100/1 T15          | 3100                | 450                | 18.0                  | 24.0                        | Custom Design     |             | 500-3200  |
| 3400/1 T16          | 3400                | 450                | 20.0                  | 26.0                        | Custom Design     |             | 500-3200  |

# Pipe(Tubular) Conveyor Belt



Pipe conveyor is a well-rounded solution for securing materials over the long distance transportation. Minimizing dust pollution and keep environment clean, it is easily conforms to complicated topography by going ups and downs and marking turns with less land required.

The pipe conveyor belt is with long transverse stiffness, excellent overlap sea and reduced buckling and minimized seam rotation in curves.

The carcass is selected according to belt tensile.

# Pipe(Tubular) Conveyor Belt

Cover: Abrasive Resistance /Heat Resistant/Acid, Alkali Resistant /Fire Retardant /Energy Saving Low Rolling Resistance  
 Max. Loading Factor 75%  
 Max. Material Particle: 30% of pipe inside diameter

| JIS Standard |                 |           | Chemical Industry Standard(GB) |                 |           | Mechanical Industry Standard (GB) |           |
|--------------|-----------------|-----------|--------------------------------|-----------------|-----------|-----------------------------------|-----------|
| Nom.Dia(mm)  | Act.Out.Dia(mm) | Width(mm) | Nom.Dia(mm)                    | Act.Out.Dia(mm) | Width(mm) | Act.Out.Dia(mm)                   | Width(mm) |
| 100          | 111.4           | 430       |                                |                 |           | 100                               | 360       |
| 150          | 165.5           | 600       |                                |                 |           | 150                               | 560       |
| 200          | 217.5           | 780       | 200                            | 218             | 800       | 200                               | 730       |
| 250          | 284.4           | 1000      | 250                            | 282             | 1000      | 250                               | 910       |
| 300          | 308.9           | 1100      | 300                            | 308             | 1100      | 300                               | 1100      |
| 350          | 360.9           | 1300      | 350                            | 361             | 1300      | 350                               | 1280      |
| 400          | 456.6           | 1600      | 400                            | 457             | 1600      | 400                               | 1460      |
|              |                 |           |                                |                 |           | 450                               | 1640      |
| 500          | 542.7           | 1900      | 500                            | 543             | 1850      | 500                               | 1820      |
|              |                 |           |                                |                 |           | 560                               | 2050      |
| 600          | 637.5           | 2250      | 600                            | 610             | 2250      | 600                               | 2190      |
|              |                 |           |                                |                 |           | 630                               | 2300      |
| 700          | 724.6           | 2550      | 700                            | 728             | 2450      |                                   | 2550      |

# Popular in Cement

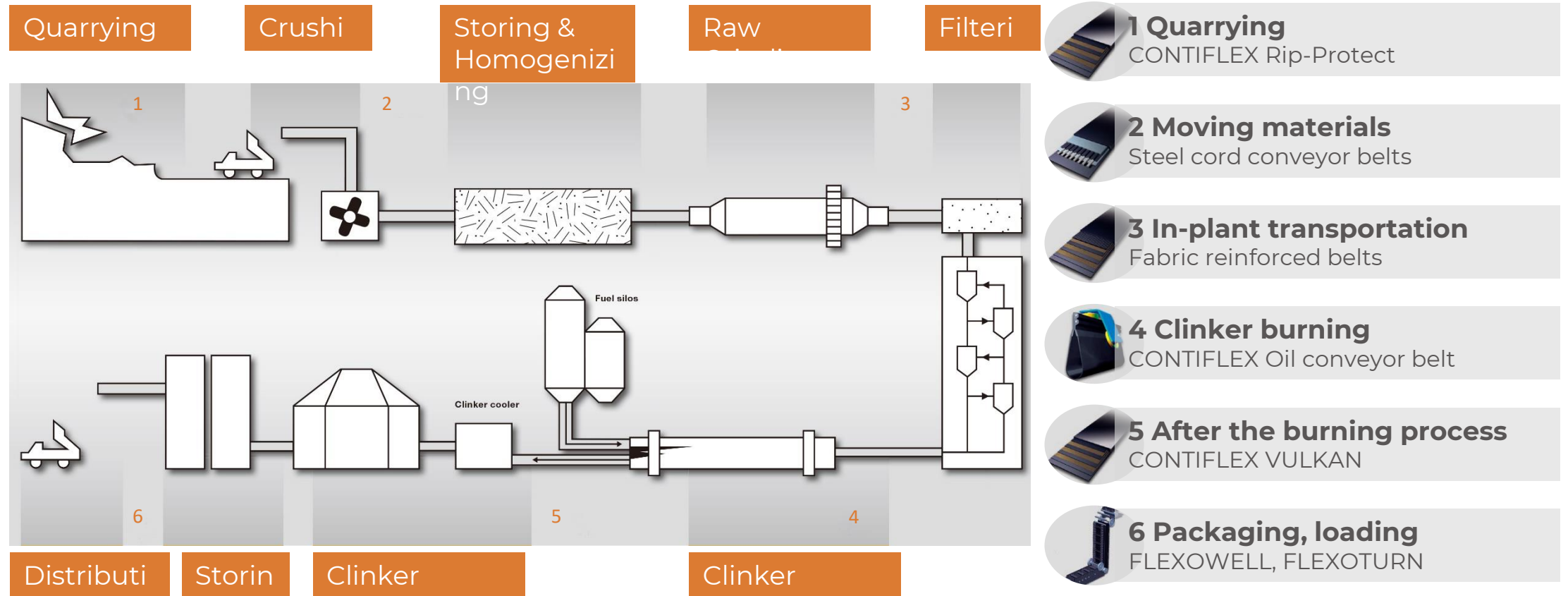

# Popular in Cement

## Steel Cord Conveyor Belts



# Complete Service



Customized Design by CETEC



ISO9001 Production



Strictly Delivery Period

Annually Site Service



Quick Response



Regularly Upgrade



# Projects

Limestone long belt conveyor in Lagos, Nigeria

Collecting Working Conditions



Technical Analysis



Reselection & Design

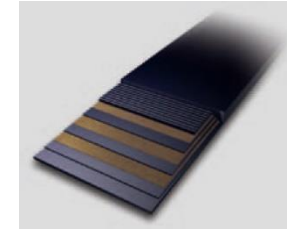

Shipping & Delivery

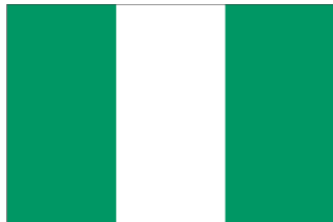

Packing & Dispatching



Processing & Production



# Projects

LafargeHolcim (Nigeria) Installation at Site









Thank You



+86 010 6445 0371



+86 010 6442 3609



[cetec@cetecchina.com](mailto:cetec@cetecchina.com)